

Hamilton 96 Technical Information

Standard Equipment

- Up to 99% efficient
- Copper 4-pass heat exchanger
- Stainless steel secondary heat exchanger
- Modulating temperature control mixing valve
- Variable speed blower
- UV flame detection
- FM/CSD-1 compliant gas train (subject to local codes)
- Mounted & wired flow switch
- Integral primary pump
- Full modulation 4:1
- No de-rate to 6000 ft.
- Sealed combustion/direct vent
- HeatNet control
- Gasketless heat exchanger assembly

Optional Equipment

- Cupro-nickel finned tubes
- BACnet or LonWorks interface module
- Freeze protection package
- Honeywell keyboard display module S7800
- Outdoor sensor with housing
- Outdoor installation

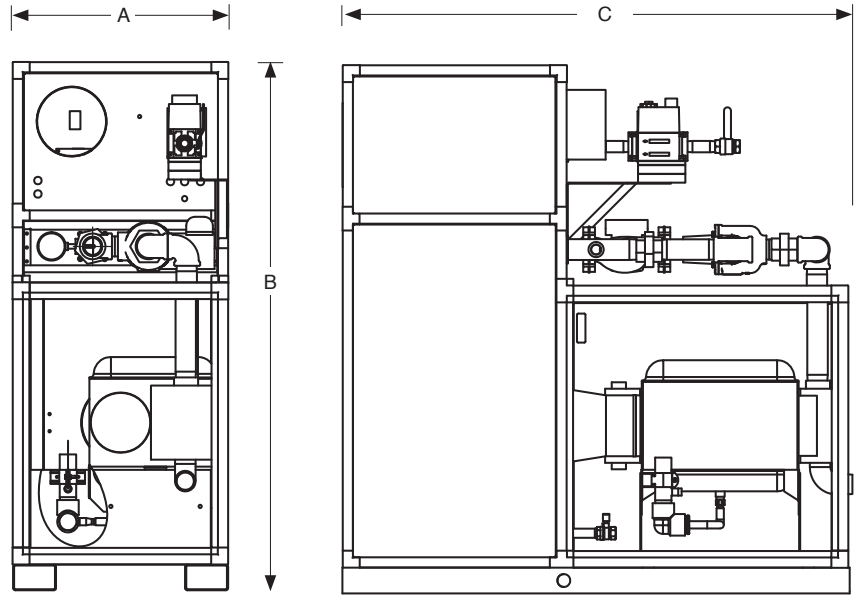

Model	Input MBTU/hr	Output MBTU/hr	GPH @ 80°F Recovery (Inlet)	GPH Recovery @ 80°F ΔT	Inlet Air	Gas Conn.	Water Conn.	A	B	C	Shipping Weight
HX 500	500	490	777	76	8"	1"	2"	25.13"	48.5"	59.0"	566 lbs.
HX 750	750	728	1,020	86	8"	1"	2"	25.13"	55.0"	59.0"	695 lbs.
HX 1000	1,000	970	1,278	92	8"	1.25"	2"	25.13"	61.5"	59.0"	705 lbs.
HX 1250	1,250	1,200	1,801	81	10"	1.25"	2.5"	29.13"	55.5"	66.5"	800 lbs.
HX 1500	1,500	1,440	2,203	86	10"	1.25"	2.5"	29.13"	60.0"	66.5"	863 lbs.
HX 1750	1,750	1,663	2,218	91	12"	1.5"	2.5"	29.13"	64.5"	66.5"	1054 lbs.
HX 2000	1,999	1,899	2,527	91	12"	1.5"	2.5"	29.13"	69.0"	66.5"	1133 lbs.

*Dimensions are approximate. Please consult factory before installation.

Model	Flue Vent		
	Category IV Positive (up to 60°F)		Category II Negative
	UL Stainless	PVC/PP	
HX 500	7"	8"	7"
HX 700	7"	8"	7"
HX 1000	7"	8"	8"
HX 1250	8"	8"	8"
HX 1500	8"	8"	8"
HX 1750	10"	10"	10"
HX 2000	10"	10"	10"

